

CCPA-100-3

FICHE TECHNIQUE / SPEC SHEET

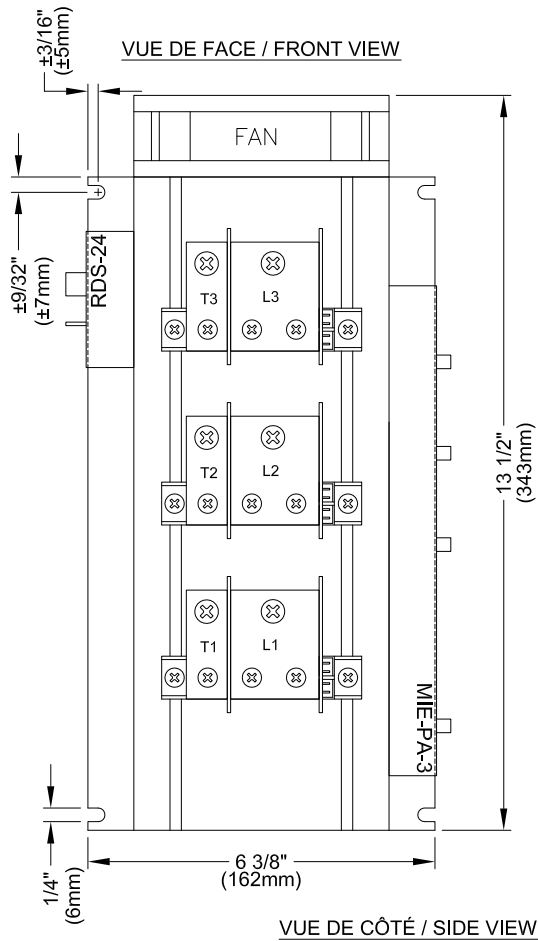

SPECIFICATIONS:

MODULES DE PUISSANCE / POWER MODULES : TYPE THYRISTORS
VENTILATEUR / FAN : 150 CFM
RADIATEUR / HEATSINK : TYPE 62905
ALIMENTATION REQUISE / REQUIRED SUPPLY : 24VAC
CONTRÔLE MODULANT / MODULATING CONTROL : TYPE PHASE ANGLE
SIGNAL DE CONTRÔLE / CONTROL SIGNAL : 0-10VDC OU/OR 4-20mA
MODÈLE / MODEL : CCPA-100-3
COURANT / AMPERAGE : 100A
VOLTAGE : 48VAC @ 600VAC, 3 PHASES

↑
**DIRECTION D'AIR /
 AIR FLOW**

L1, L2 & L3 = LIGNES / LINES
 T1, T2 & T3 = CHARGES / LOADS

VUE DU HAUT / TOP VIEW

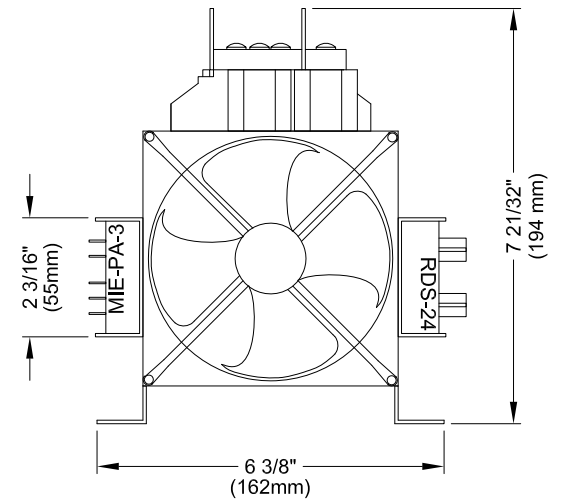
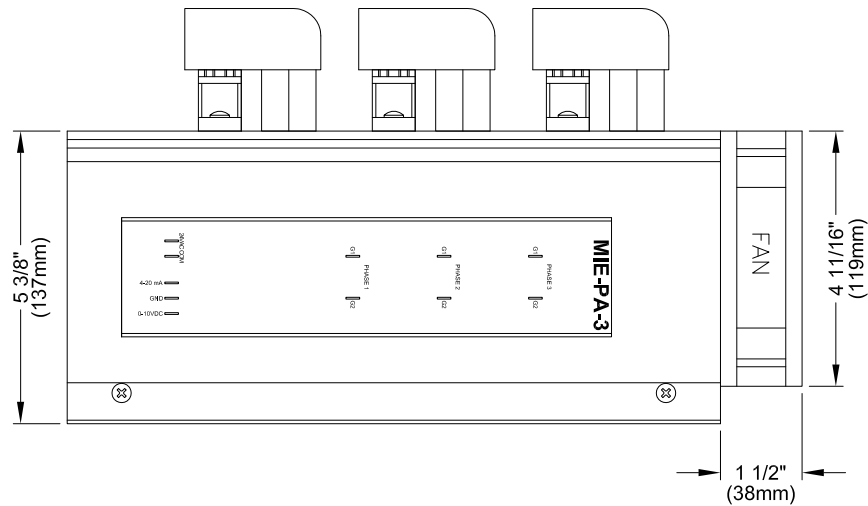

CRISTAL

2025 LAVOISIER #135
 QUEBEC, QC, CANADA
 G1N 4L6
 TEL: 1-800-681-9590
 FAX: 1-418-681-7393
www.cristalcontrols.com



C US
 CAN/CSA-C22.2 NO. 14-M95
 -APPAREILLAGE INDUSTRIEL DE COMMANDE
 UL Std No. 508
 -INDUSTRIAL CONTROL EQUIPMENT

- PROPOSITION
- APPROBATION
- INFORMATION

Préparé par: LT, Vérifié par: PC

DESSIN / DRAWING :

CCPA-100-3

DATE :

MARS 2012