

CCPA-200-1

FICHE TECHNIQUE / SPEC SHEET

VUE DE FACE / FRONT VIEW

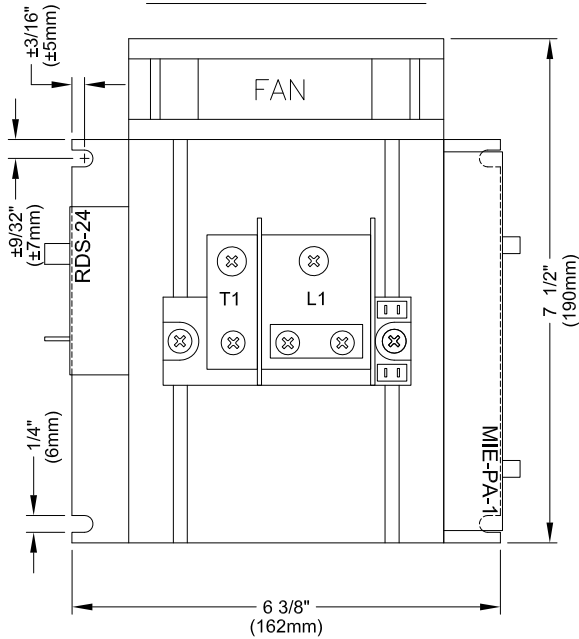

SPECIFICATIONS:

MODULE DE PUISSANCE / POWER MODULE : TYPE THYRISTOR
RADIATEUR / HEATSINK : TYPE 62905
VENTILATEUR / FAN : 110 CFM
ALIMENTATION REQUISE / REQUIRED SUPPLY : 24VAC
CONTRÔLE MODULANT / MODULATING CONTROL : TYPE PHASE ANGLE
SIGNAL DE CONTRÔLE / CONTROL SIGNAL : 0-10VDC OU/OR 4-20mA
MODÈLE / MODEL : CCPA-200-1
COURANT / AMPERAGE : 200A
VOLTAGE : 48VAC @ 600VAC, 1 PHASE

NOTE: "LUGS" NON-INCLUS / LUGS NOT INCLUDED



DIRECTION D'AIR /
AIR FLOW

L1 = LIGNE / LINE
T1 = CHARGE / LOAD

VUE DE CÔTÉ / SIDE VIEW

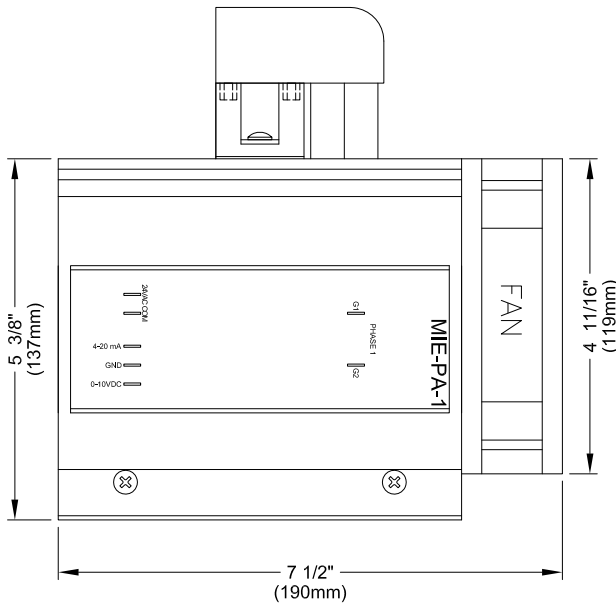

VUE DU BAS / BOTTOM VIEW

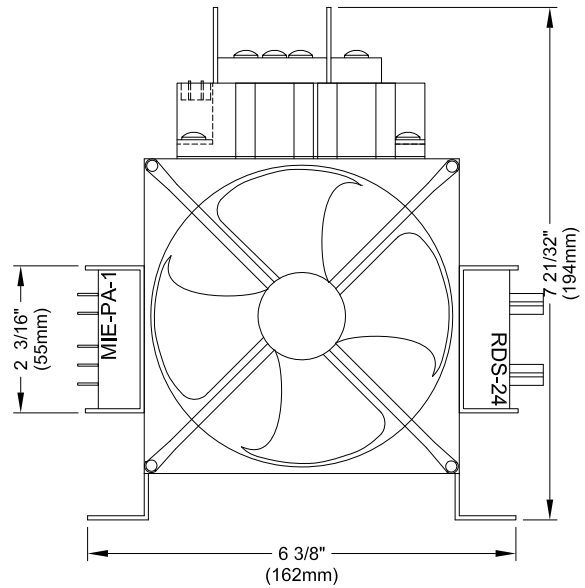

CRISTAL

2025 LAVOISIER #135
 QUEBEC, QC, CANADA
 G1N 4L6
 TEL: 1-418-681-9590
 FAX: 1-418-681-7393
www.cristalcontrols.com

Pour information /
 For information
 Cristal Controls
1-800-681-9590

- PROPOSITION
 - APPROVAL
 - INFORMATION
- Préparé par: LT, Vérifié par: PC

DESSIN / DRAWING :

CCPA-200-1

DATE :

MARS 2012