

CCPA-200-3

FICHE TECHNIQUE / SPEC SHEET

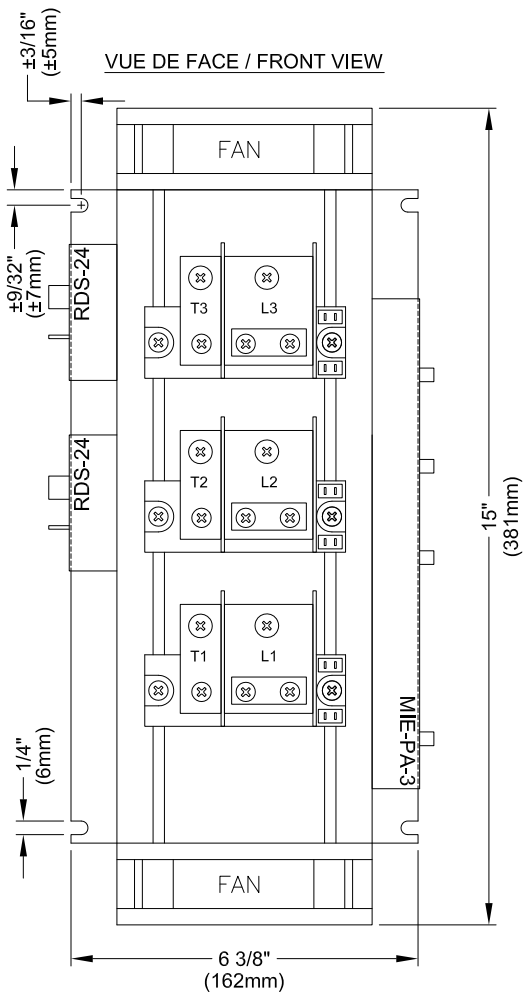

SPECIFICATIONS:

- MODULES DE PUISSANCE / POWER MODULES :** TYPE THYRISTORS
- VENTILATEURS / FANS :** 110 CFM CHAQUE / EACH
- RADIATEUR / HEATSINK :** TYPE 62905
- ALIMENTATION REQUISE / REQUIRED SUPPLY :** 24VAC
- CONTRÔLE MODULANT / MODULATING CONTROL :** TYPE PHASE ANGLE
- SIGNAL DE CONTRÔLE / CONTROL SIGNAL :** 0-10VDC OU/OR 4-20mA
- MODÈLE / MODEL :** CCPA-200-3
- COURANT / AMPERAGE :** 200A
- VOLTAGE :** 48VAC @ 600VAC, 3 PHASE (3 LEGS)



DIRECTION D'AIR /
AIR FLOW

L1, L2 & L3 = LIGNES / LINES
T1, T2 & T3 = CHARGES / LOADS

VUE DE CÔTÉ / SIDE VIEW

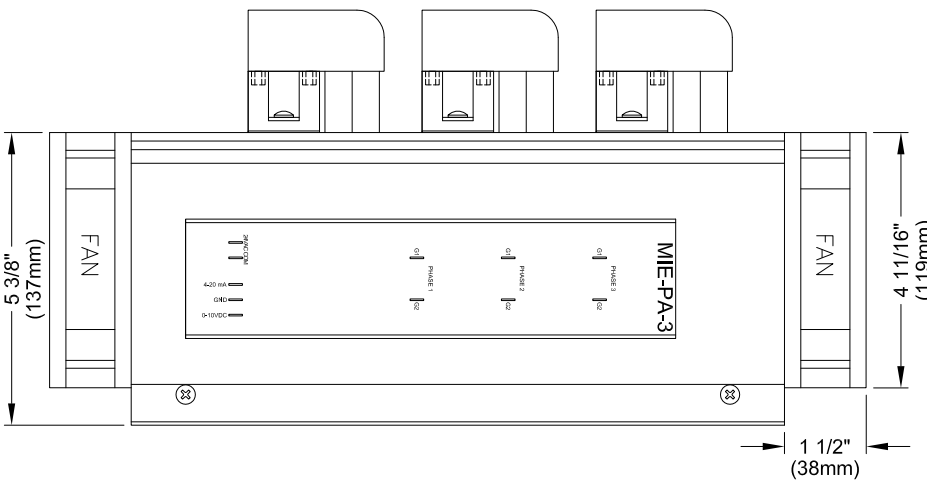

VUE DU BAS / BOTTOM VIEW

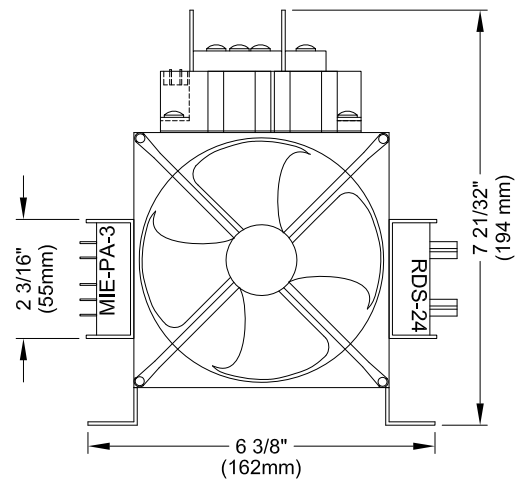

CRISTAL

2025 LAVOISIER #135
QUEBEC, QC, CANADA
G1N 4L6
TEL: 1-800-681-9590
FAX: 1-418-681-7393
www.cristalcontrols.com



CAN/CSA-C22.2 NO. 14-M95
-APPAREILLAGE INDUSTRIEL DE COMMANDE
UL Std No. 508
-INDUSTRIAL CONTROL EQUIPMENT

- PROPOSITION
- APPROBATION
- INFORMATION

Préparé par: LT, Vérifié par: PC

DESSIN / DRAWING :

CCPA-200-3

DATE :

MARS 2012