

# CCPA-300-1

## FICHE TECHNIQUE / SPEC SHEET

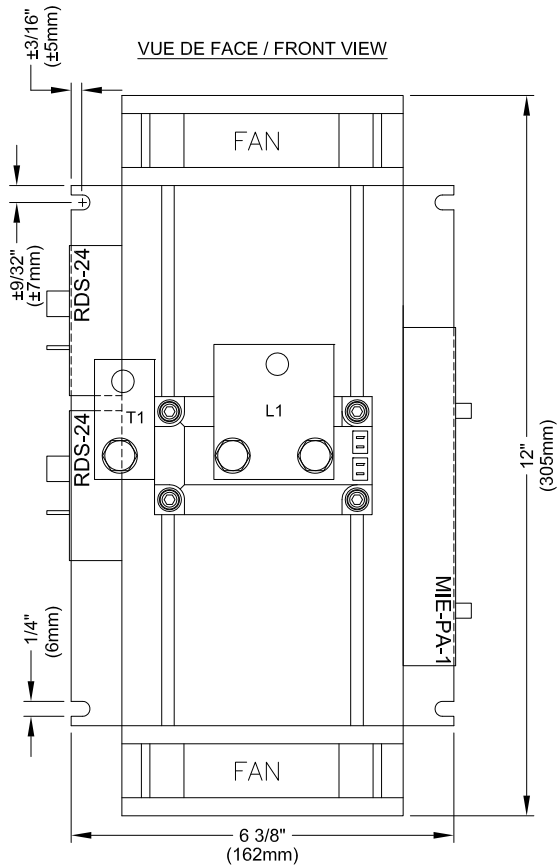

**SPECIFICATIONS:**

**MODULES DE PUISSANCE / POWER MODULES :** TYPE THYRISTORS  
**RADIATEUR / HEATSINK :** TYPE 62905  
**VENTILATEUR / FAN :** 110 CFM CHAQUE / EACH  
**ALIMENTATION REQUISE / REQUIRED SUPPLY :** 24VAC  
**CONTRÔLE MODULANT / MODULATING CONTROL :** TYPE PHASE ANGLE  
**SIGNAL DE CONTRÔLE / CONTROL SIGNAL :** 0-10VDC OU/OR 4-20mA  
**MODÈLE / MODEL :** CCPA-300-1  
**COURANT / AMPERAGE :** 300A  
**VOLTAGE :** 48VAC @ 600VAC, 1 PHASE

NOTE: "LUGS" NON-INCLUS / LUGS NOT INCLUDED

↑  
DIRECTION D'AIR / AIR FLOW

L1 = LIGNE / LINE  
T1 = CHARGE / LOAD

VUE DE CÔTÉ / SIDE VIEW

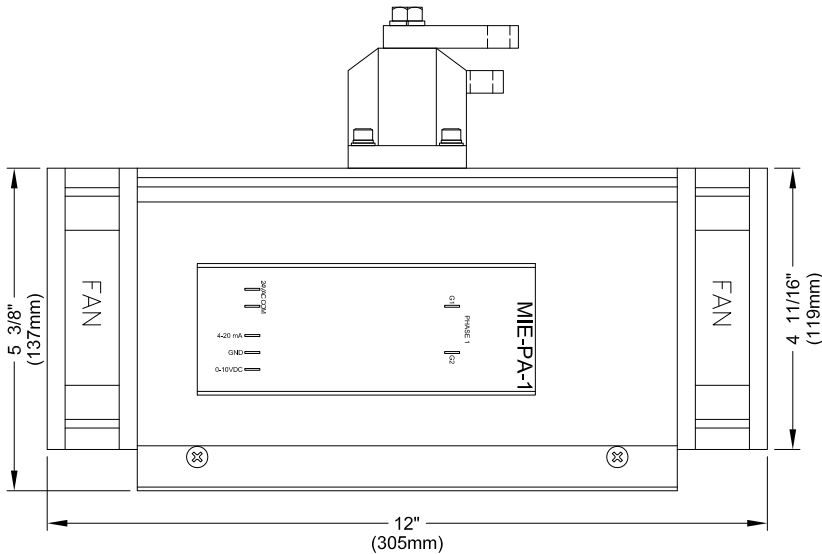

VUE DU BAS / BOTTOM VIEW

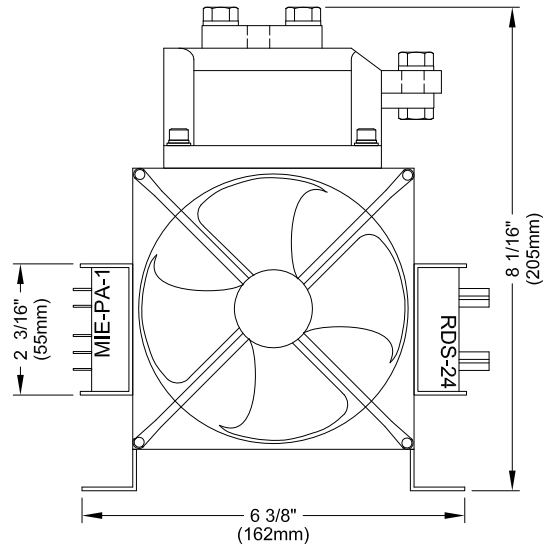

**CRISTAL**

2025 LAVOISIER #135  
 QUEBEC, QC, CANADA  
 G1N 4L6  
 TEL: 1-800-681-9590  
 FAX: 1-418-681-7393  
[www.cristalcontrols.com](http://www.cristalcontrols.com)



C US  
 CAN/CSA-C22.2 NO. 14-M95  
 -APPAREILLAGE INDUSTRIEL DE COMMANDE  
 UL Std No. 508  
 -INDUSTRIAL CONTROL EQUIPMENT

PROPOSITION  
 APPROBATION  
 INFORMATION  
 Préparé par: LT, Vérifié par: PC

DESSIN / DRAWING :

CCPA-300-1

DATE :

MARS 2012