

# CCPA-50-3

## FICHE TECHNIQUE / SPEC SHEET

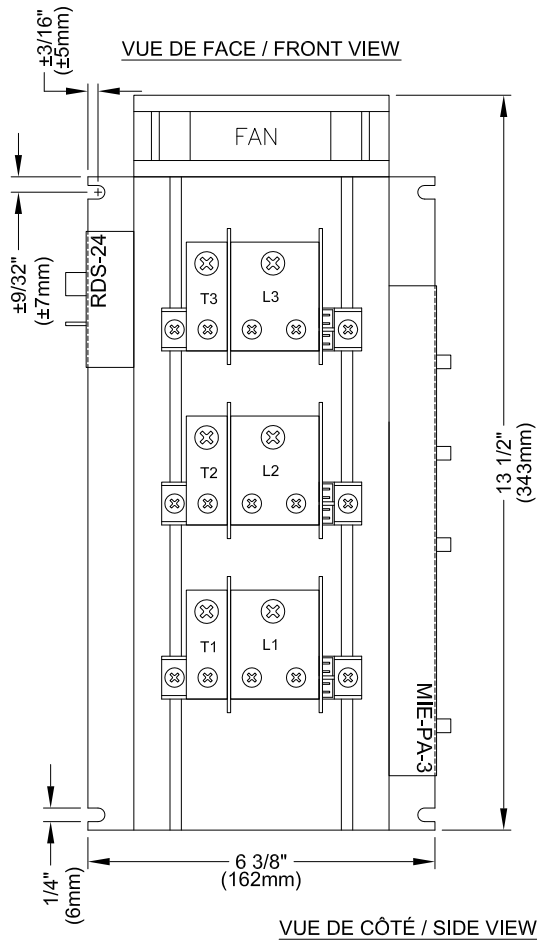

**SPECIFICATIONS:**

**MODULES DE PUISSANCE / POWER MODULES :** TYPE THYRISTORS  
**VENTILATEUR / FAN :** 150 CFM  
**RADIATEUR / HEATSINK :** TYPE 62905  
**ALIMENTATION REQUISE / REQUIRED SUPPLY :** 24VAC  
**CONTRÔLE MODULANT / MODULATING CONTROL :** TYPE PHASE ANGLE  
**SIGNAL DE CONTRÔLE / CONTROL SIGNAL :** 0-10VDC OU/OR 4-20mA  
**MODÈLE / MODEL :** CCPA-50-3  
**COURANT / AMPERAGE :** 50A  
**VOLTAGE :** 48VAC @ 600VAC, 3 PHASES

↑  
**DIRECTION D'AIR /  
 AIR FLOW**

L1, L2 & L3 = LIGNES / LINES  
 T1, T2 & T3 = CHARGES / LOADS

**VUE DU HAUT / TOP VIEW**

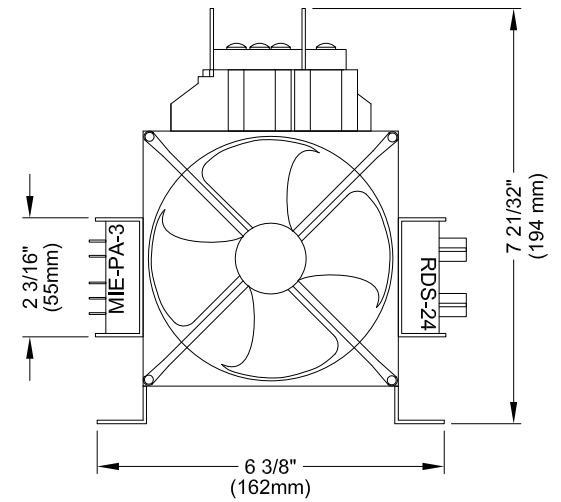
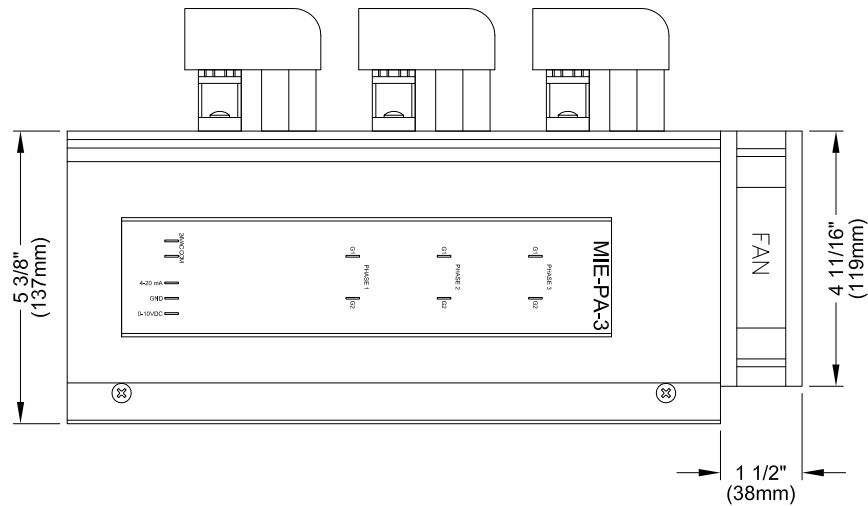

**CRISTAL**

2025 LAVOISIER #135  
 QUEBEC, QC, CANADA  
 G1N 4L6  
 TEL: 1-800-681-9590  
 FAX: 1-418-681-7393  
[www.cristalcontrols.com](http://www.cristalcontrols.com)



C US  
 CAN/CSA-C22.2 NO. 14-M95  
 -APPAREILLAGE INDUSTRIEL DE COMMANDE  
 UL Std No. 508  
 -INDUSTRIAL CONTROL EQUIPMENT

- PROPOSITION
- APPROBATION
- INFORMATION

Préparé par: LT, Vérifié par: PC

DESSIN / DRAWING :

CCPA-50-3

DATE :

MARS 2012