

# CCS-350-3

## FICHE TECHNIQUE / SPEC SHEET

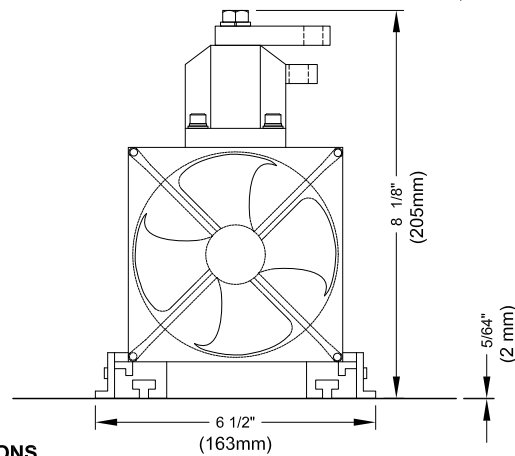
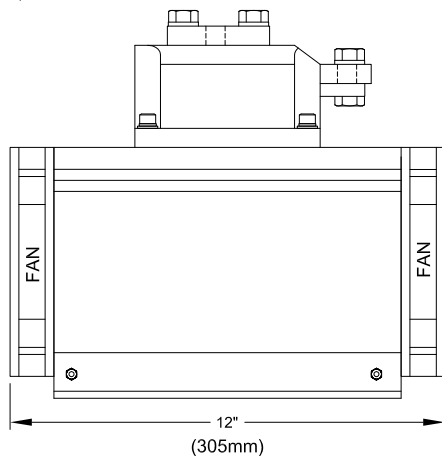
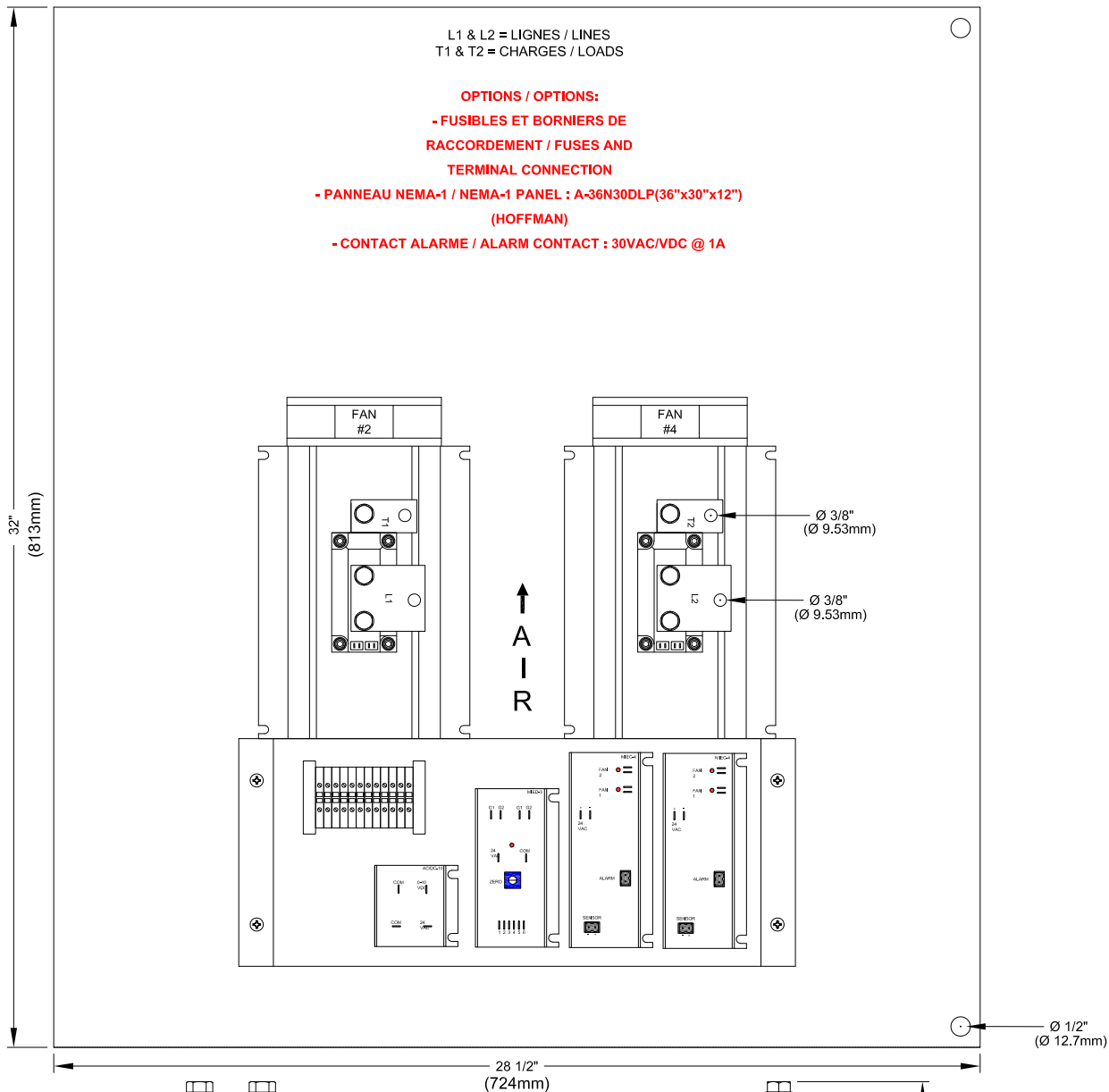

### SPECIFICATIONS

**MODULES DE PUISSANCE / POWER MODULES :** TYPE THYRISTORS  
**RADIATEUR / HEATSINK :** TYPE 62905  
**VENTILATEURS / FANS :** 110 CFM CHAQUE / EACH  
**\*ALIMENTATION REQUISE / REQUIRED SUPPLY :** 24VAC @ 100VA  
**FOURNIE PAR ÉLECTRICIEN / SUPPLIED BY ELECTRICIAN**  
**CONTRÔLE MODULANT / MODULATING CONTROL :** MIED-3

**SIGNAL DE CONTRÔLE / CONTROL SIGNAL :** 0-10Vdc & 4-20mA  
**MODÈLE / MODEL :** CCS-350-3  
**COURANT / AMPERAGE :** 350A  
**VOLTAGE :** 48VAC - 600VAC, 3 PHASES (2 LEGS), 50-60Hz  
**OPÉRATION PAR PASSAGE À ZÉRO / ZERO-CROSS OPERATION**  
**PLAQUE / PLATE :** A-36N30MP (HOFFMAN)



2025 LAVOISIER #135  
 QUEBEC, QC, CANADA  
 G1N 4L6  
 TEL: 1-800-681-9590  
 FAX: 1-418-681-7393  
[www.cristalcontrols.com](http://www.cristalcontrols.com)



C US  
 CAN/CSA-C22.2 NO. 14-M95  
 -APPAREILLAGE INDUSTRIEL DE COMMANDE  
 UL Std No. 508  
 -INDUSTRIAL CONTROL EQUIPMENT

- PROPOSITION
  - APPROBATION
  - INFORMATION
- Préparé par: LT, Vérifié par: PC

DESSIN / DRAWING :

CCS-350-3

DATE :

MARS 2012