

CCT-300-1

FICHE TECHNIQUE / SPEC SHEET

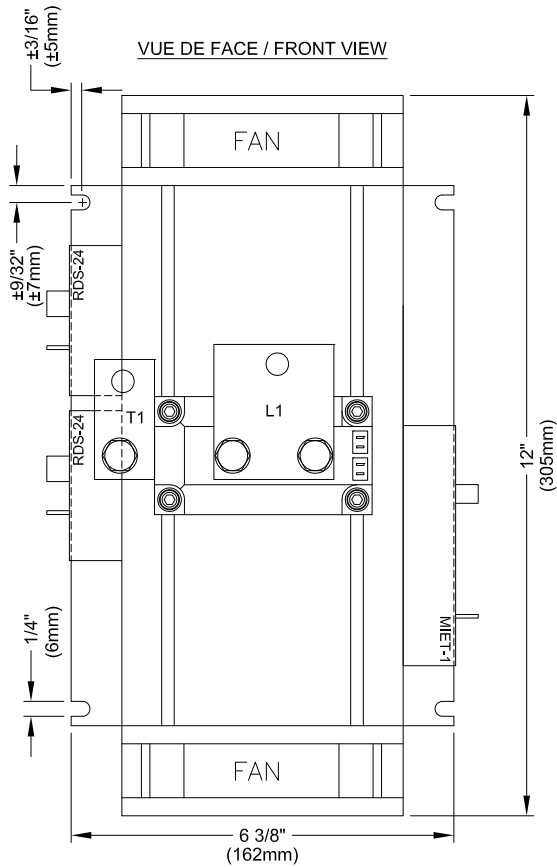

SPECIFICATIONS:

MODULES DE PUISSANCE / POWER MODULES : TYPE THYRISTORS
RADIATEUR / HEATSINK : TYPE 62905
VENTILATEUR / FAN : 110 CFM CHAQUE / EACH
ALIMENTATION REQUISE / REQUIRED SUPPLY : 24VAC
MODULE DE CONTRÔLE / CONTROL MODULE : MIET-1
SIGNAL DE CONTRÔLE / CONTROL SIGNAL : 3-32Vdc, 24Vac
MODÈLE / MODEL : CCT-300-1
COURANT / AMPERAGE : 300A
VOLTAGE : 48VAC @ 600VAC, 1 PHASE
OPÉRATION PAR PASSAGE À ZÉRO / ZERO-CROSS OPERATION

NOTE: "LUGS" NON-INCLUS / LUGS NOT INCLUDED

↑
DIRECTION D'AIR / AIR FLOW

L1 = LIGNE / LINE
T1 = CHARGE / LOAD

VUE DE CÔTÉ / SIDE VIEW

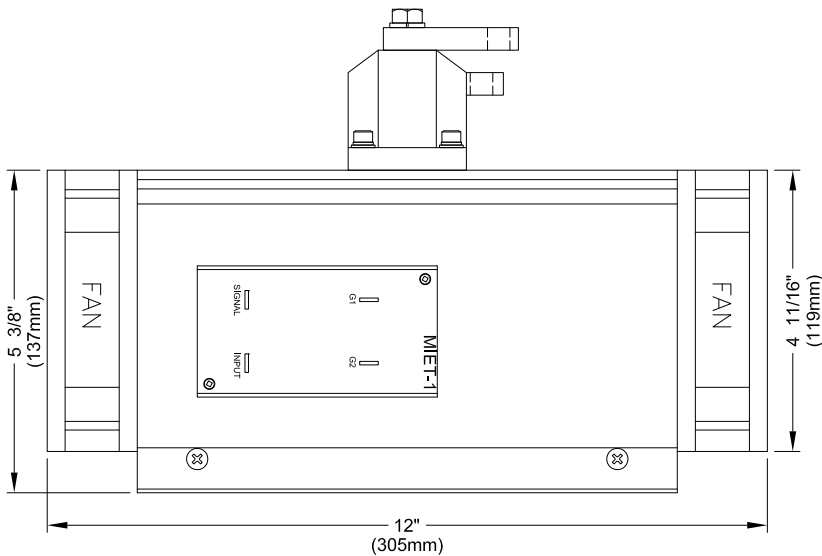

VUE DU BAS / BOTTOM VIEW

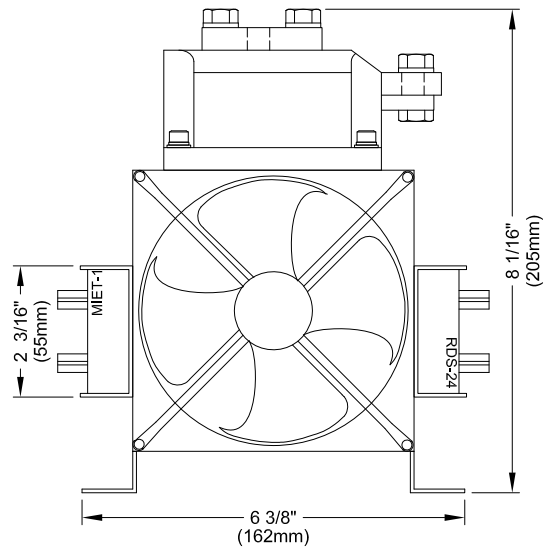

CRISTAL

2025 LAVOISIER #135
 QUEBEC, QC, CANADA
 G1N 4L6
 TEL: 1-800-681-9590
 FAX: 1-418-681-7393
www.cristalcontrols.com



CAN/CSA-C22.2 NO. 14-M95
 -APPAREILLAGE INDUSTRIEL DE COMMANDE
 UL Std No. 508
 -INDUSTRIAL CONTROL EQUIPMENT

PROPOSITION
 APPROBATION
 INFORMATION
 Préparé par: LT, Vérifié par: PC

DESSIN / DRAWING :

CCT-300-1

DATE :

MARS 2012